

Controlled Energy Corp.

340 Mad River Park
Waitsfield, VT 05673
Tel. (800) 642-3111

**Tech support is available at
www.controlledenergy.com**



MODEL AQUASTAR 240 FX

Suitable for water (potable) heating only

WATER HEATER

Manufactured by Takagi Industrial Co. USA Inc.
The Aquastar name is trademarked and licensed by Bosch.

FEATURES

- ENDLESS HOT WATER
- ON DEMAND, NO STAND-BY LOSS
- COMPACT, SAVE SPACE
- CONSERVES ENERGY
- COMPUTER CONTROLS
- COMPUTERIZED SAFETY
- NO PILOT LIGHT

AVAILABLE ACCESSORIES (see p.16)

- REMOTE THERMOSTAT –240TSTAT
- WALL SUPPORT BRACKETS – 240BRACKET
- HORIZONTAL VENT TERMINATOR WITH DRAFT DAMPER - FXHOOD

**AUTOMATIC
INSTANTANEOUS WATER HEATER**

**INSTALLATION AND OWNER'S
MANUAL**

FOR YOUR SAFETY - This product must be installed and serviced by a professional service technician, qualified in water heater installation. Installation and/or operation could create carbon monoxide gas and flue gases, which could cause serious injury or death. Improper installation and/or operation will void the warranty. In the Commonwealth of Massachusetts this product must be installed by a licensed plumber.

WARNING: If the information in this manual is not followed exactly, a fire or explosion may result, causing property damage, personal injury or death.

- Do not store or use gasoline or other flammable vapors and liquids in the vicinity of this or any other appliance.
- WHAT TO DO IF YOU SMELL GAS
 - Do not try to light any appliances.
 - Do not touch any electrical switch, also do not use any phone in your building.
 - Immediately call your gas supplier from a neighbor's phone. Follow the gas supplier's instructions.
 - If you cannot reach your gas supplier, call the fire department.
- Installation and service must be performed by a qualified installer, service agency or the gas supplier.

TABLE OF CONTENTS

For Your Safety	3
Operation	4
• General	4
• Normal Operation	4
• Start Up	4
• Temperature	4 & 22
• Freeze Prevention	4
• Winterizing	5
Installation	5
• General	5
• Outdoor Installation	6
• Indoor Installation	7
• High Altitude	7
• Combustion Air	8
• Venting	8
• Manufactured Home (Mobile home) and Recreation Park Trailer Installation	10
• Gas Supply	10
• Water Connections	12
• Pressure Relief Valve	12
• Electrical Connection	13
• Wiring Diagram	14
Initiating the Heater	15
Accessories	16
Maintenance and Service	17
Trouble Shooting	17
Common Questions	17
Part List	21

SPECIFICATIONS

Natural Gas Input	Min. 37,000 Btu Max. 165,000 Btu
LP Gas Input	Min. 35,000 Btu Max. 165,000 Btu
Gas Connection	¾" NPT
Water Connections	¾" NPT
Water Pressure	Min. 15 psi Max. 150 psi
Natural Gas Pressure before appliance:	Min. 5" WC Max. 10.5" WC
LP Gas Pressure before appliance:	Min. 11" WC Max. 14" WC
Manifold Pressure*	Natural 3.5" WC LP Gas 4.0" WC
<i>*measured with a maximum hot water flow rate (5.3 gallon per minute)</i>	
Weight	60 lbs.
Dimensions	24 ½" x 16 ½" x 8 ¼"
Ignition	Electronic Ignition
Electrical Supply	AC 120 V less than 2 amp

- Inlet gas pressure before appliance must not exceed above value.
- For gas pressures lower than 5" WC for Natural Gas or 11" WC for LPG, do not install until gas pressure is corrected.
- Check the rating plate to insure this product matches your specifications.
- High Altitude installations: see p.7
- Takagi - USA is constantly improving its products, therefore specifications are subject to change without prior notice.

FOR YOUR SAFETY

PLEASE, READ CAREFULLY THIS MANUAL AND FOLLOW IT FOR YOUR SAFETY.

1. **Follow all local codes, or in the absence of local codes, follow the most recent edition of the National Fuel Gas Code, ANSI Z223.1/NFPA 54 in the USA.**
2. Properly ground the unit in accordance with all local codes or in the absence of local codes, with the National Electrical Codes, ANSI/NFPA 70 in the USA or CSA standard C22.1 Canada Electrical Code Part 1 in Canada.
3. Carefully plan where to install water heater. Correct combustion air supply and flue pipe installation are very important. If not installed correctly, fatal accidents can be caused by lack of air, carbon monoxide poisoning or fire. Locate water heater where water leakage will not do damage to surrounding areas. If there is a possibility of water damage install a suitable drain pan under the unit that will not restrict combustion air.
4. National Fire and Building Codes do not allow a gas fired water heater installation in a bathroom, bedroom or any occupied room normally kept closed. The place where you install the heater must have enough ventilation.
5. Check the rating plate for the correct gas type, gas pressure, water pressure, and electrical rating before installing it.

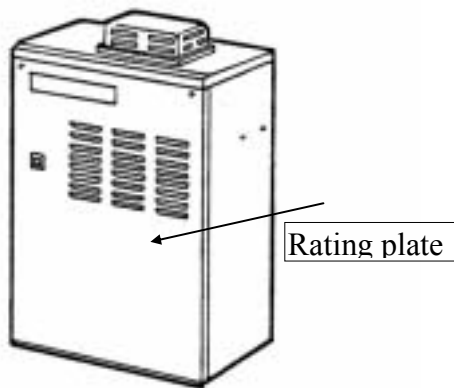

6. If any problem should occur, turn off all hot water taps and turn off the gas. Then call a trained technician, the Gas Company or Controlled Energy.
7. **WARNING :** Do not disconnect the electrical supply if the temperatures will be near freezing. The Freeze Prevention Device only works if the unit has proper electrical power. In outdoor installations the Freeze Prevention Device is rated for temperatures down to 5°F (-15°C) in a wind free environment. The wind chill factor will cause the AQ240FX Water Heater to freeze and be damaged at temperatures above 5°F (-15°C). Due to this we strongly recommend

that the 240FX only be installed outside in warm or mild climates. Locations with winter temperatures that regularly drop below freezing are not recommended. Refer to the section on Winterizing and Freeze Prevention Device for more information.

8. **WARNING :** Before bathing or showering always check the water temperature. Do not leave children or the infirm unsupervised in the shower or bath. The water temperature is set at 122°F (50°C) from the factory to maximize the amount of hot water you can use. See p.4
9. **WARNING :** Do not use this appliance if any part has been underwater. Immediately call a certified gas technician to inspect and service the unit if necessary.
10. **WARNING :** Do not store or use gasoline or other flammable vapors and liquids in the vicinity of this or any other appliance.
11. **WARNING :** Do not reverse the water and gas connections as this will damage the water heater and can cause severe injury or death from scalds. Follow the diagram below when installing the AQ240FX water heater.
12. **WARNING :** The heater may still operate when improperly installed. It will, however, be less efficient and could eventually damage the heater. It could even result in human sickness or death due to oxygen deprivation and carbon monoxide poisoning.

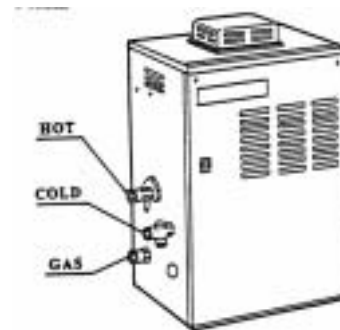

OPERATION

General

The AQ240FX Water Heater is an instantaneous, tankless water heater designed to supply household and commercial hot water with total efficiency. The principle behind the AQ240FX Water Heater is simple. Once you open a hot water tap, water flows through the water heater. The water flow sensor signals the computer to electronically ignite the burners and the computer monitors the water temperature, volume of water, and gas flow to insure you get the right amount of hot water. After the burners are ignited the "fire on" lamp is lit.

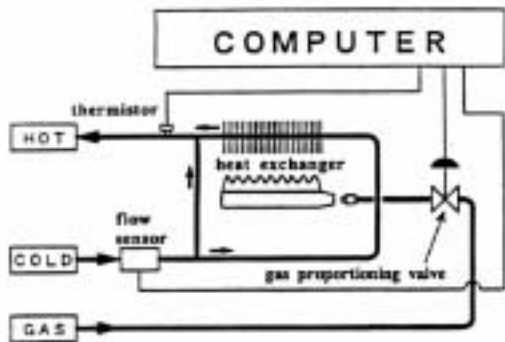

The burners activate at a .75 gallon per minute flow rate. After the burners are ignited, the flow rate can be lowered to 0.6 gallons per minute to maintain the heater on.

Now as long as you have water, adequate gas supply and electricity, you will get an endless flow of hot water. Open a hot water tap to turn on the water heater. Close the tap to turn off the water heater.

Normal Operation

To Turn on water heater

1. Open a hot water tap.
2. Burners ignite, "Fire On" lamp is lit and the exhaust fan operates.



3. Mix with cold water to get the correct temperature water.



To Turn off your water heater

1. Close the hot water tap

2. "Fire On" lamp extinguished, the exhaust fan will continue to operate for 70 seconds.



Start Up

Once the unit has been properly installed, check the gas and water connections for leaks. Check for proper ventilation and combustion air to the heater. **Purge the gas and water lines to remove debris.** Then follow these steps to turn on your unit.

1. Close the manual gas control valve located on the gas line.
2. Fully open the manual water control valve on the water supply line.
3. Open a hot water tap, to verify that water will flow to that tap. Then close the hot water tap.
4. Fully open the manual gas control valve installed.
5. Turn on the 120 volt 60 Hz power supply to the water heater.

Temperature

The 240FX has been set at the factory to deliver 122° F (50° C) water. This is electronically controlled by the computer. When drawing hot water, mix with cold water if necessary to get a desired temperature.

See degree rise table on page 22.

WARNING : Temperatures above 125° F (52° C) can cause severe burns or death from scalding. Children, the disabled and the elderly are at high risk of being injured. Feel the water temperature before bathing or showering. Do not leave children, disabled, and the elderly unsupervised.

The inlet water temperature will dictate how much hot water you can produce, but you will not be able to produce more than 5.3 gallons per minute of hot water because there is a flow governor restricting the water flow.

Freeze Prevention Devices

This unit comes equipped with heaters that discourage the unit from freezing in an outdoor

installation. For this freeze prevention system to operate there has to be electrical power to the unit.

The freeze prevention devices will not work if the electrical power source is disconnected. The unit has been rated for temperatures down to 5° F (-15° C) in a wind free environment. The wind chill factor will cause the unit to freeze at temperatures above 5° F (-15° C). Due to this we strongly recommend that the 240FX only be installed outside in warm or mild climates. Locations with winter temperatures that regularly drop below freezing are not recommended. **Do not install the water heater in an area with extremely cold weather.** This will void your warranty and Controlled Energy will not be responsible for any damage that occurs.

CAUTION : The pipe heaters are located on the AQ240FX Water Heater only. Any hot or cold water pipes located outside of the unit will not be protected. Properly protect and insulate these pipes from freezing.

Controlled Energy strongly recommends the use of its CSA approved vent terminator with a built in back draft flapper for any Horizontally vented indoor installations where outside temperatures will be below freezing. Without it negative air can freeze the copper heat exchanger in the AQ240FX when not in use. If this type of vent terminator was not purchased with the heater and you are in a cold climate, please contact your distributor or Controlled Energy to order. Item FXHOOD

Winterizing

If you will not be using your heater for a long period of time or if the temperatures will drop below 5° F (-15° C) with the wind chill factor, turn off your heater and drain the unit of water. This will keep your unit from freezing and being damaged. Follow these instructions carefully:

1. Turn off the power supply to the Water Heater.
2. Turn off the manual gas shut off valve located outside your heater.
3. Turn off the manual water shut off valve located on the water supply line. See Fig. A
4. Open all hot water taps in the house. (Bathroom, kitchen, laundry room, etc.). When the water flow has ceased, close all hot water taps.
5. Have a bucket or pan to catch the water from the units drain plugs. Remove the drain plugs to drain all the water out of the unit.
6. Leave for 5 minutes.
7. Securely screw the drain plugs back into place.

Now when you want to use your heater again follow these steps:

1. Make sure all hot water taps are closed and the drain plugs are securely attached.
2. Purge the water line of debris.
3. Turn on the manual water control valve located on the water supply line.
4. Open all the hot water taps to verify water flows to the taps. Then close hot water taps.
5. Turn on the manual gas control valve located on the gas supply line.
6. Turn on the power supply to the AQ240FX Water Heater.

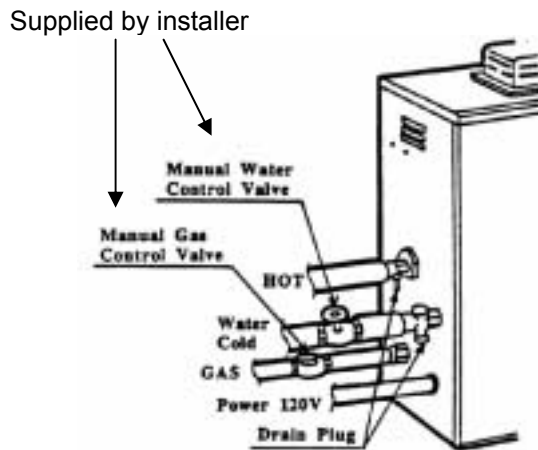

Fig. A

INSTALLATION

Please keep this owner's manual in a safe place for future reference. Copies of this manual are available from Controlled Energy

This section is for the installer. The installer is responsible for the correct installation of your AQ240FX Water Heater.

For Your Safety : Only a gas technician or qualified plumber may service or install your product.

General

All gas water heaters require careful and correct installation to insure safe and efficient operation. This manual must be followed exactly.

1. Read the **For Your Safety** section in the beginning of this manual.

2. This unit is not capable of being used as a pool or spa heater, nor is it certified for space heating.
3. The internal gas regulator is preset at the factory. It is computer controlled and should not need adjustment. Do not supply unit with inlet gas pressure that exceeds the specified maximum amount on page 2 of this manual.
4. Suitable for potable water heating only.
5. Maintain proper space for servicing. Install the unit so that it can be connected or removed easily.
6. The electrical connection requires a means for switching off the power supply.
7. Avoid installing the unit in an area with high levels of dust, sand or debris. Impure particles from these objects may clog the air vent or reduce functions of the rotating fan and cause incomplete combustion.
8. Do not install the unit where the exhaust vent is pointing into any opening in a building. For horizontally vented installations: **Do not install exhaust vent against vinyl siding.** Allow exhaust vent to mount flush to a non plastic surface such as pine board or plywood and maintain at least a 3 inch clearance from the vinyl.
9. The 240FX can be wall supported Indoors or Outdoors using the 240BRACKET accessory. See page 13. These wall support brackets are required when wall hanging. Floor mounted installations require use of the smaller Wall Mount Brackets. See pages 6-7 and table below. Additional strapping to prevent tipping or falling in earthquake-prone zones may be required. Check local codes.

OUTDOOR INSTALLATION

Follow all local codes and in the absence of local codes, follow the National Fuel Gas Code ANSI Z221.23 in the USA.

Locate the water heater in an open, unroofed area, and maintain the following minimum clearances from combustible and noncombustible materials.





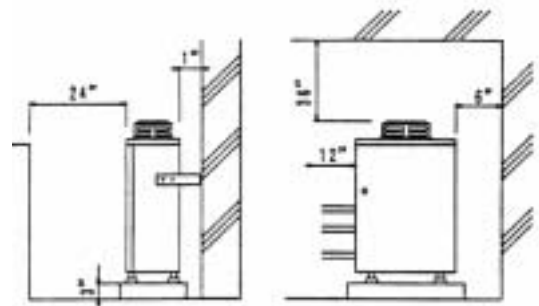

Piping side	12"
Front (Maintenance space)	24"
Floor	Non combustible base Min. 3" off the ground
Back of heater	1"
Non piping side	6"
Top of heater	36"

Do not install this water heater under an overhang, less than 3 feet from its top. The area under an overhang must be open to three sides.



Included Accessories

Check that all parts listed below were included with the unit.

PARTS NAME	SHAPE	NUMBER
Pressure Relief Valve		1
Manual		1
Washers		4
Screws		4
Wall Mount Brackets		2
Anchor		4

When installing the AQ240FX on a placement stand, be sure to adjust the legs so that it stands level and secure. (Adjustable legs can be moved up to 1")

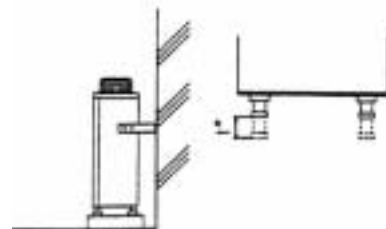

Use the two L shaped Wall Mount Brackets to securely attach the AQ240FX to a wall surface. Use a screw to attach the longer part of the wall mount bracket temporarily to the heater and determine screw positions on the wall. Then drill a 1/4" hole in the wall. Insert anchor. Tighten all 4 screws. Minimum clearance behind the heater is 1".

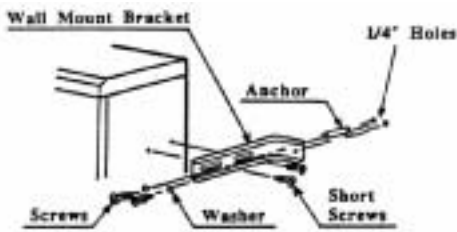

WARNING : Do not have the flue terminal pointing toward any opening into a building. Do not locate your heater in a pit or location where gas and water can accumulate.

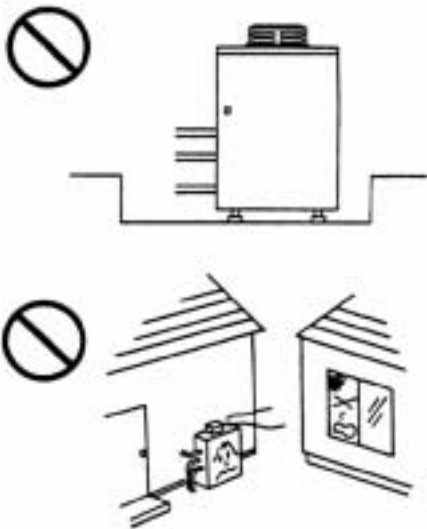

WARNING : Do not install the heater where water, debris, or flammable vapors may get into the flue terminal. This may cause damage to the heater.

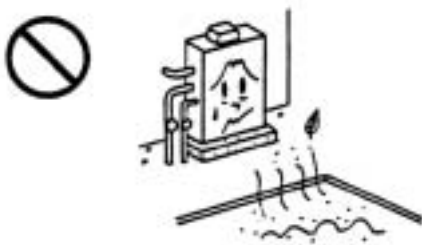

WARNING : Do not install the heater with the vent within 4 feet of any opening into a building.



WARNING: Improper installation can cause nausea or asphyxiation from carbon monoxide and flue gases which could result in severe injury or death.

FOR HIGH ALTITUDE INSTALLATIONS ABOVE 5,000 FEET

The btu output of the AQ240FX will be reduced 4% for each 1,000 feet over 5,000 feet. The computer operation of the heater properly monitors the btu output and combustion quality of the heater up to a 5,000 foot elevation. Above 5,000 feet this will result in lower degree rise. For installations above 10,000 feet please contact CEC.

INDOOR INSTALLATION

Mounting the heater: Review mounting bracket options in section 9 on page 6.

Follow all local codes and in the absence of local codes, follow the National Fuel Gas Code ANSI Z221.23 in the USA.

FOR INDOOR INSTALLATION REMOVE OUTDOOR VENT CAP AND *CUT PRESSURE SWITCH JUMP WIRE THEN INSTALL 4" VENTING DIRECTLY ON FLUE OUTLET. * : PLEASE! Look inside unit.

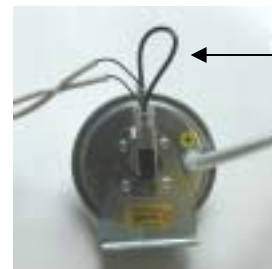

See p. 13 for Fan Pressure Switch location in heater

For indoor installations only, cut this wire. Be sure to place wire nuts on the cut ends. Once cut, this safety pressure switch will be ready to shut the heater off if the unit is inadequately or improperly venting.

Clearances

Piping side	Min. 6"
Front (Maintenance space)	Max. 24" Min. 4"
Floor	Noncombustible base
Back of heater	1"
Non piping side	Min. 2"
Top of heater	11"

Combustion Air Supply

The water heater location must be provided with a proper amount of combustion air. See the latest edition of ANSI Standard Z223.1 and any local codes that are applicable.

DO NOT INSTALL DIRECTLY ON CARPETING.

In general these requirements specify that if the unit is installed in a confined space there must be permanent air supply openings.

Minimum size of open space required for 240FX

Water heater size	Volume	Area with an 8 Ft. ceiling
165,000 BTU	8,250 Cubic Ft.	1,031 Square Ft.

If the 240FX is installed in an area smaller than indicated above, then the installer must make special provisions for combustion air in the form of two openings, one within 12" of the top and one within 12" of the bottom of the space, each having a total free area of 1 square inch per 1,000 BTUH of rated input if the air is taken from inside the house. This requirement reduces to 1 square inch per 4,000 BTUH if the air is taken from the outside.

See the National Fuel Gas Code for alternate methods.

OUTSIDE AIR SUPPLY; when combustion air is supplied directly through an outside wall, such as intake louver openings into the dwelling. Each opening should give a minimum free area of one square inch per 4000 BTUH input of the total input rating of all combustion appliances in the enclosed area.

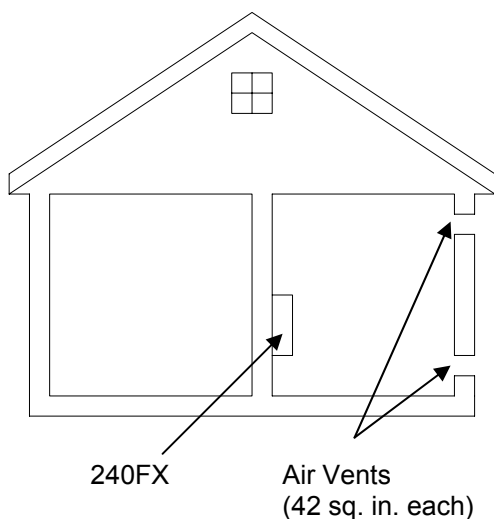

INSIDE AIR SUPPLY; when combustion air is supplied from inside the building. Each opening of the closet door should have a minimum free area of one square inch per 1000 BTUH input of the total input rating of all appliances in the enclosed area.

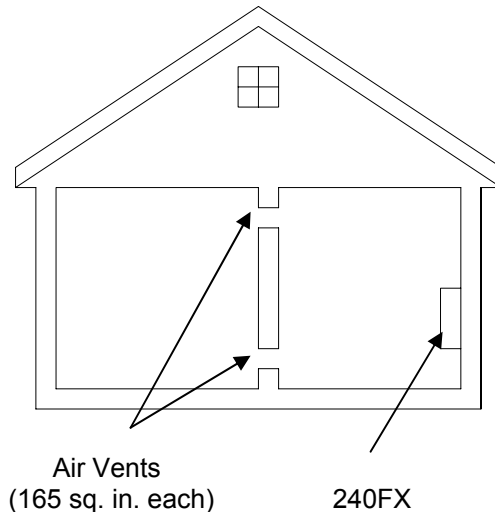

VENTING

This Category III water heater must be vented in accordance with Venting of Equipment, of the latest edition of the National Fuel Gas Code.

WARNING : Improper venting of this appliance can result in excessive levels of Carbon Monoxide which can result in severe personal injury or death.

Vent Connections

This Category III water heater is listed for use with single wall stainless (AL29-4C) or galvanized vent pipe of 26 minimum gauge and must maintain a 3" clearance to combustibles. Use of a special gas vent listed for Type II, III and IV is recommended but not required. Manufacturers include FasNSeal, Z-Flex and Heat-Fab. Follow clearances and sealing methods specified by those manufacturers. If local codes supercede national codes (NFGC and IFGC), a greater clearance to combustibles may be required. Always check with your local plumbing or mechanical inspector before installing.

The vent system must be gas tight. All seams and joints must be sealed with silicone sealant that has a minimum temperature rating of 350° F. For best results, horizontal and vertical vent systems should be as short and straight as possible.

Double wall type B-vent is not permitted or approved for Category III Appliances.
Do not common vent the 240FX with any other vented appliance.

The entire vent system must not exceed the size specified in the following table.

Diameter	Max. No. of Elbow	Max. Vertical or Horizontal run in Length
4"	3 Ea.	21 ft

Subtract 5 feet for each elbow. Example: 11 ft. is the maximum total distance if two elbows are used.

When the horizontal vent run exceeds 5 ft. the following criteria must be observed;

- Attach a vertical pipe at least 2" high to the water heater outlet before the horizontal run.
- Support the vent run at 3 ft intervals with overhead hanger.
- Pitch up the vent run toward the vent terminal at a rate of 1/ 4" per foot.

If Horizontally Venting:

A listed side wall vent terminator must be used when the water heater is vented through a side wall. The FXHOOD is recommended. The terminator provides a means of installing vent pipe through the building wall and must be located in accordance with ANSI Z223.1 and local applicable codes. **See page 5 for indoor freeze prevention and recommended vent terminator to be used.**

Side wall exit locations for mechanical draft vent terminals

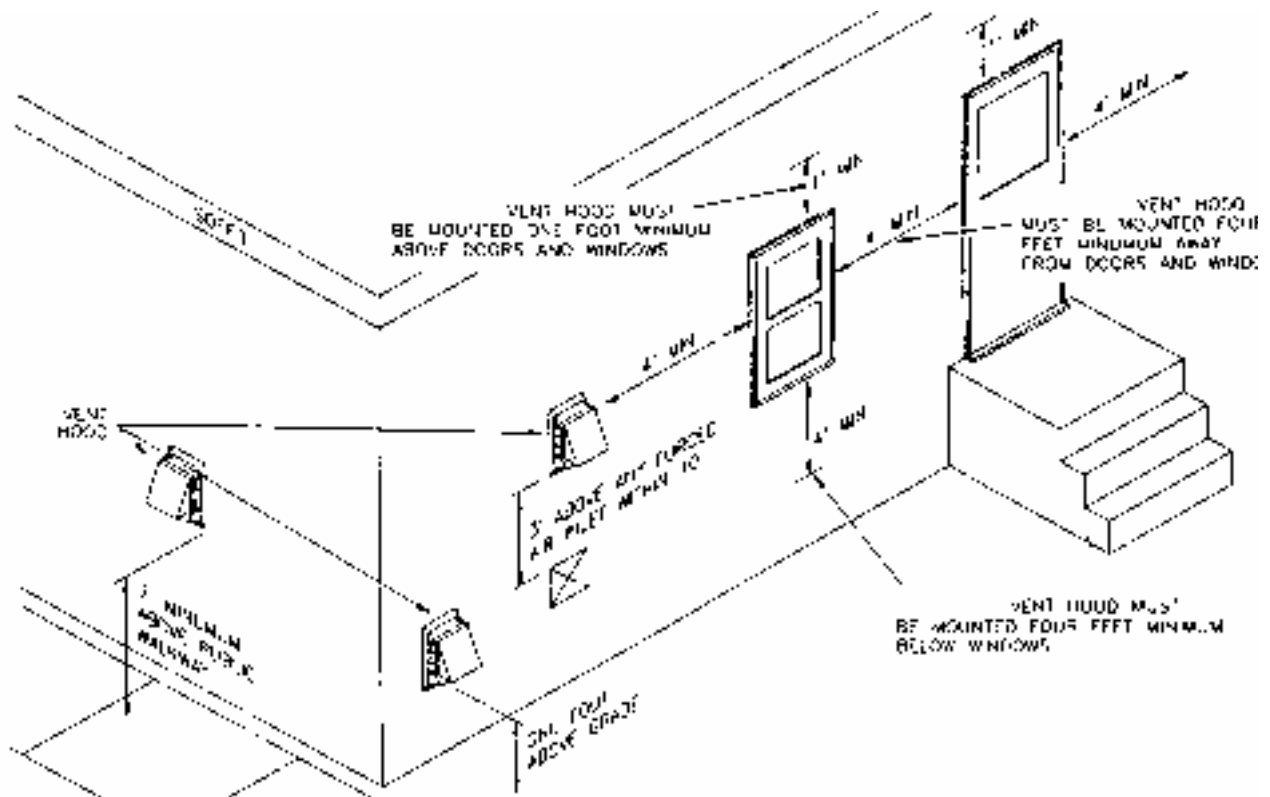

GAS SUPPLY AND PIPING

If Vertically Venting:

Follow the vent length specifications in table on page 9 and use a listed vent cap.

MANUFACTURED HOME (MOBILE HOME) and RECREATIONAL PARK TRAILERS

WARNING : Read and Review this entire Manual with special emphasis on the Combustion and Ventilation for your safety.

This appliance must be installed in accordance with the Manufactured Home Construction and Safety Standard (Title 24, CFR ; Part 3280) and ANSI A119.5 for Recreational Park Trailers, the following instructions supplied with the vent termination, local codes and utility company requirements governing the installation of water heaters in manufactured home (mobile home) and Recreational Park Trailers and/or in the absence of local codes, the latest edition of the National Fuel Gas Code, ANSI Z 223.1/NFPA 54 and ANSI A119.5/NFPA 501D.

Location for a Manufactured Home (Mobile Home) and Recreational Park Trailers

This water heater must be installed within an enclosure to separate the water heater's combustion and venting system from the interior atmosphere of the manufactured home or trailer. All air for combustion must be obtained from the outside atmosphere. And the products of combusted gases (flue gases) must be discharged directly to the outside through the gas vent. There must not be any door or other opening into the water heater enclosure from the inside of the manufactured home. Please refer to installation diagrams and freeze protection information

Placement of Water Heater: Locate the water heater as desired, make certain the minimum clearances are maintained. For indoor installation follow page 7-9, and outdoor installation follow page 6-7, please see section for manufactured home and recreational park trailer outdoor installation.

Indoor installation for a Manufactured Home (Mobile Home) and Recreational Park Trailers

Same as typical house installation except, all air for combustion must be obtained from the outside atmosphere for manufactured home. Please see page 8 for indoor installation.

This unit requires a gas control shut-off valve to be supplied by the installer. It must be placed on the unit before it is connected to the gas line. Check that the gas inlet pressure and the type of gas matches the rating plate located on your water heater. Insufficient gas pressure will cause your AQ240FX Water Heater to be inefficient and not work properly. Size the gas piping correctly.

For up to 25ft. ¾" Black Iron pipe is the minimum pipe size required for Natural Gas.

For up to 25ft. ½" Black Iron is the minimum pipe size required for LP.

For up to 10ft. 5/8" Copper is the minimum pipe size required for LP.

Flex lines are not recommended, oversize if one needs to be used.

See Gas Sizing tables on page 11.

Minimum and maximum inlet gas pressures are as follows:

Natural Gas	Min. 5" WC Max. 10.5" WC
Propane Gas	Min. 11" WC Max. 14" WC

Maximum gas pressures must not exceed this value.

After the connections are complete check for gas leaks by applying soapy water to all gas fittings and connections. Soap bubbles are a sign of gas leaks. This appliance must be isolated from the gas supply piping system by unplugging the unit and disconnecting the main gas during any pressure testing of the gas supply piping system at test pressures equal to or more than ½ Psi. The appliance and its gas connections must be leak tested before placing the unit in operation. Always use approved connectors to connect the unit to the gas line. Always purge the gas line of any debris before connection to the heater. **WARNING:** Conversion of this unit from natural gas to propane or propane to natural gas cannot be done. Contact your local retailer or distributor to get the correct unit for your gas type.

Check the rating plate to make sure that the unit is labeled for the type of gas available in the area.

The gas supply piping should be sized according to the Applicable Plumbing Code for a maximum draw of 165,000 BTUH. First determine the effective length of the gas supply line by measuring the actual length of piping, and then adding 5 ft. for every elbow or "T" to the actual length. Use the charts below to determine the pipe diameter necessary to accommodate the BTU demand of the unit. If there are more gas drawing appliances on the line, size according to the maximum amount of BTU demand.

Natural Gas Supply Piping (Black Iron) – inside diameter

Based on 0.60 specific gravity for natural gas at .5" WC pressure drop
DOE standard is 1100 BTU per cubic ft. of natural gas

Btu numbers given in thousands

Pipe Size	Cubic Feet of Natural Gas													
	Length	10'	20'	30'	40'	50'	60'	70'	80'	90'	100'	125'	150'	200'
½"	132	92	73	63	56	50	-	-	-	-	-	-	-	-
¾"	278	190	152	130	115	105	96	-	-	-	-	-	-	-
1"	520	350	285	245	215	195	180	170	160	150	130	120	100	
1 ¼"	1050	730	590	500	440	400	370	350	320	305	275	250	210	
1 ½"	1600	1100	890	760	670	610	560	530	490	460	410	380	320	
2"	3050	2100	1650	1450	1270	1150	1050	990	930	870	780	710	610	

Propane Supply Piping (Black Iron) – inside diameter

Based on 11" WC supply pressure

Btu numbers given in thousands

Pipe Size	kBTU of Propane													
	Length	10'	20'	30'	40'	50'	60'	70'	80'	90'	100'	125'	150'	200'
½"	275	189	152	129	114	103	-	-	-	-	-	-	-	-
¾"	567	393	315	267	237	217	196	185	173	162	146	132	112	
1"	1071	732	590	504	448	409	378	346	322	307	275	252	213	
1 ¼"	2205	1496	1212	1039	913	834	771	724	677	630	567	511	440	
1 ½"	3307	2299	1858	1559	1417	1275	1181	1086	1023	976	866	787	675	
2"	6221	4331	3465	2992	2646	2394	2205	2047	1921	1811	1606	1496	1260	

Propane Supply Piping (Copper) - outside diameter

Based on 11" WC supply pressure

Btu numbers given in thousands

Pipe Size	Length	10'	20'	30'	40'	50'	60'	70'	80'	90'	100'
5/8"	199	131	107	90	-	-	-	-	-	-	-
¾"	329	216	181	145	131	121	112	-	-	-	-
7/8"	501	346	277	233	198	187	164	155	146	138	

Water Connections

A listed manual water control valve must be placed on the cold water supply line. All soldering materials and piping materials must be useable with potable water. Don't solder connections close to the heater. If the water heater is installed in a closed water system, such as one having a backflow preventer in the cold water supply line, means shall be provided to control thermal expansion, such as a small expansion tank. Purge the water line to remove all the debris and air from it. It may damage the heater if you do not. There is a wire mesh filter to discourage debris from entering your heater. This will need to be cleaned periodically.

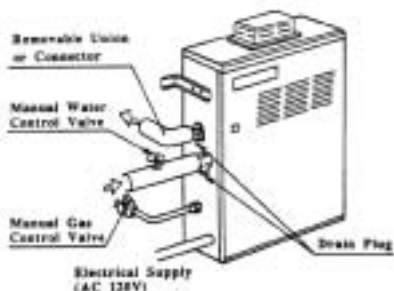
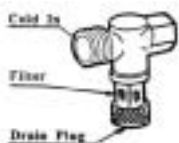

WARNING : Do not reverse the hot outlet and cold supply line connections to the AQ240FX. This will cause your heater to operate dangerously. Make sure the hot and cold lines are connected properly. Refer to the FOR YOUR SAFETY section at the front of this manual.

PRESSURE RELIEF VALVE

This unit is supplied with a listed pressure relief valve. The pressure relief valve must be installed on the hot water outlet. A "Tee" fitting should be used to attach the pressure relief valve. The pressure relief valve must not exceed the following:

Pressure Relief	150 psi
-----------------	---------

The discharge capacity must be at least 165,000 Btu/hr and the discharge opening shall be piped to a suitable drain to prevent water damage should discharge occur.

If the pressure relief valve on the appliance discharges periodically, this may be due to the thermal expansion in a closed water supply system or excessive building water pressure. Contact the water supplier or local plumber on how to correct this situation.

Do not plug the pressure relief valve. The relief line should have no reduced fittings or other restrictions and should allow for complete drainage of valve and line. The pressure relief valve must be manually operated once a year to check for correct operation.

Should overheating occur or gas supply fail to shut off, turn off the manual gas control shut-off valve to the appliance.

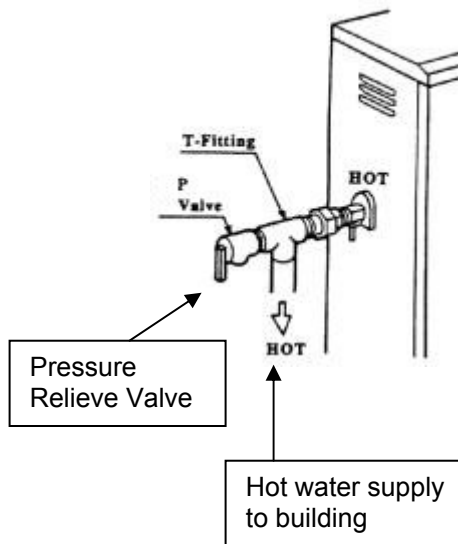

Electrical Connections

WARNING : The heater must be electrically grounded in accordance with the most recent edition of the National Electrical Code, ANSI/NFPA 70. Do not rely on the gas or water piping to ground the metal parts of the heater.

CAUTION : Label all wires prior to disconnection when servicing controls. Wiring error can cause improper and dangerous operation. Verify proper operation after servicing.

The AQ240FX requires an electrical power supply from 120 VAC 60 Hz circuit and must be properly grounded.

- A means for switching off the 120 VAC power supply must be provided.
- Wire the heater exactly as shown in the wiring diagram on page 14 and Fig B.

- A green screw is provided in the junction box for grounding connection.

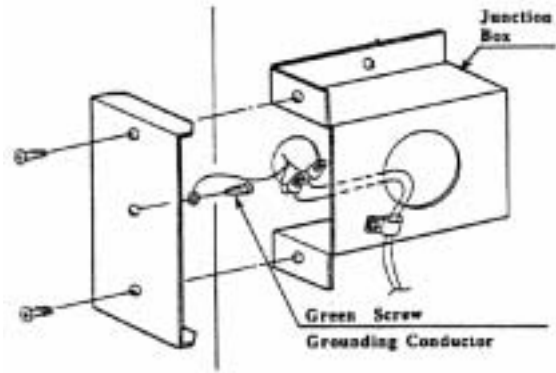
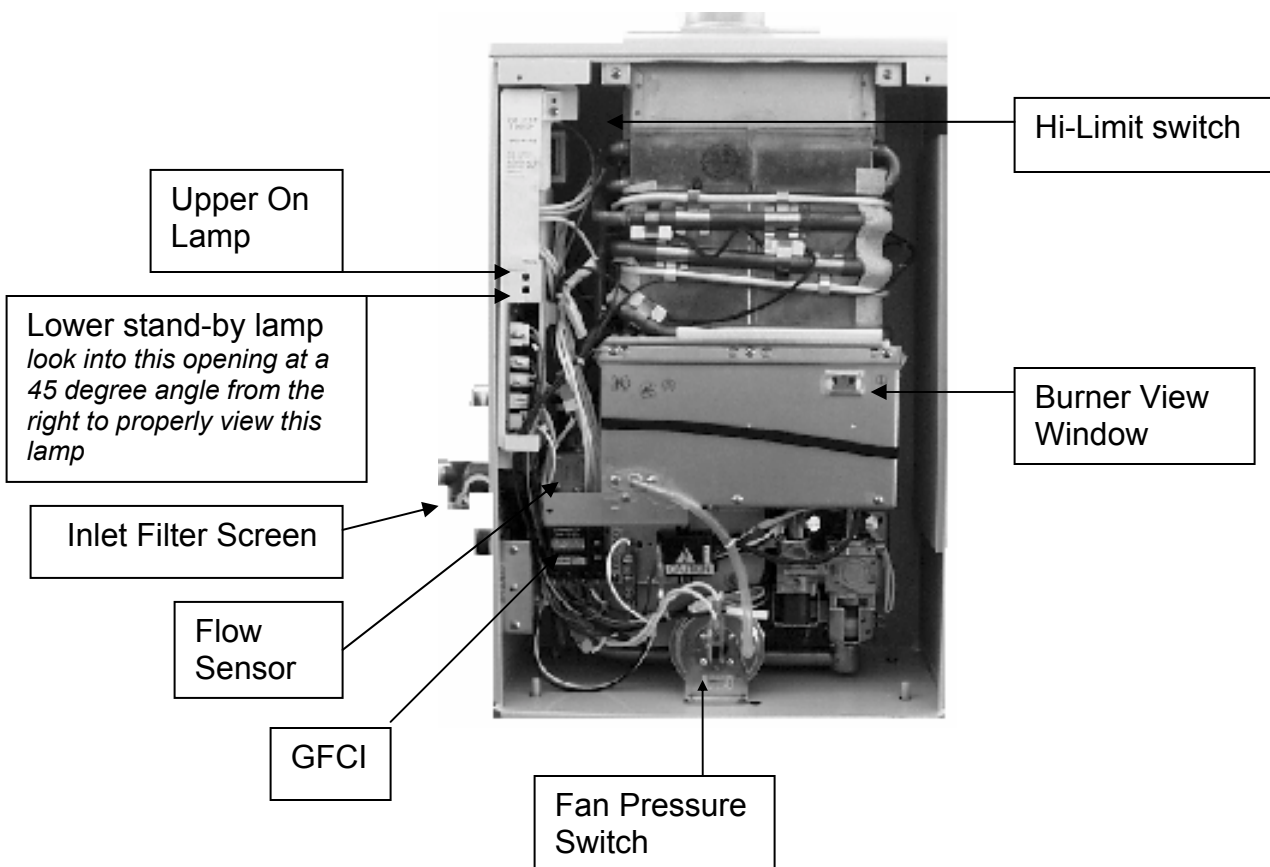

Fig. B

Refer to the wiring diagram. A wiring diagram is also located on the inside panel of the appliance.



Initiating the Heater

For your safety read before operating.

WARNING : If you do not follow these instructions exactly, a fire or explosion may result causing property damage, personal injury or loss of life.

- a) This appliance does not have a pilot. It is equipped with an ignition device, which automatically lights the burner. Do not try to light the burner by hand.
- b) Before operating smell all around the appliance area for gas. Be sure to smell next to the floor because some gas is heavier than air and will settle on the floor.
- c) Use only your hand to push in or turn the gas control knob (*manual gas valve located outside the heater*). Never use tools. If the knob (*manual gas valve located outside the heater*) will not push in or turn by hand, do not try to repair it, call a qualified service technician. Force or attempted repair may result in a fire or explosion.
- d) Do not use this appliance if any part has been under water. Immediately call a qualified gas technician to inspect the appliance and to replace any part or the control system and any gas control which has been under water.

WHAT TO DO IF YOU SMELL GAS!

- Do not try to light any appliance.
- Do not touch any electric switch, do not use any phone in your building.
- Immediately call your gas supplier from a neighbor's phone. Follow the gas supplier's instructions.
- If you cannot reach your gas supplier, call the fire department.

Operating Instructions

1. STOP! Read the safety information first!
2. Turn off electric power to the appliance.
3. Do not attempt to light the burner manually.
4. Turn the manual gas control valve located outside of the unit on the gas line counterclockwise to the closed position.
5. Wait five (5) minutes to clear out any gas. If you then smell gas, STOP! Follow "B" in the safety information above on this section. If you do not smell gas go to the next step.
6. Turn the manual gas control valve located outside of the unit on the gas line clockwise to the open position.
7. Turn on all electric power to the appliance.
8. If the appliance will not operate, follow the instructions "To Turn Off Gas to Appliance" and call your service technician or gas supplier.

TO TURN OFF GAS APPLIANCE

Close the manual gas valve on the gas inlet line. Then turn off the power supply.

ACCESSORIES



- Two 18" wide wall support brackets used for installation of Aquastar 240FX water heater on a wall surface. Part number: **240BRACKET**



- Remote temperature controller for Aquastar 240FX. The 240TSTAT is a remote control thermostat that can increase or decrease the output temperatures, turn the power to the heater on and off and diagnose errors if there is ever a failure. It connects to the heater, using 18GA thermostat wire, and can mount most anywhere in the home, 100 feet max. from the heater. The 18 gauge wire is not supplied with the 240TSTAT. Part number: **240TSTAT**

ACCESSORIES CAN BE ORDERED THROUGH YOUR DEALER OR CONTROLLED ENERGY.

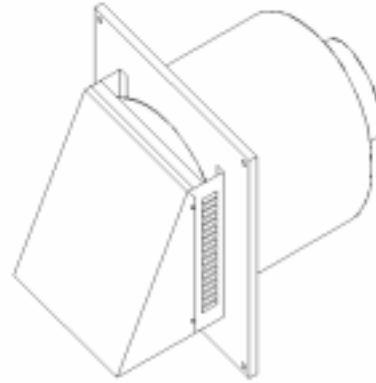

- Back draft prevention vent terminator for horizontally vented installations. Prevents cold air from blowing into the heat exchanger and harming the unit. Part number: **FXHOOD**
See installation template below.

For up to an 8 inch thick wall

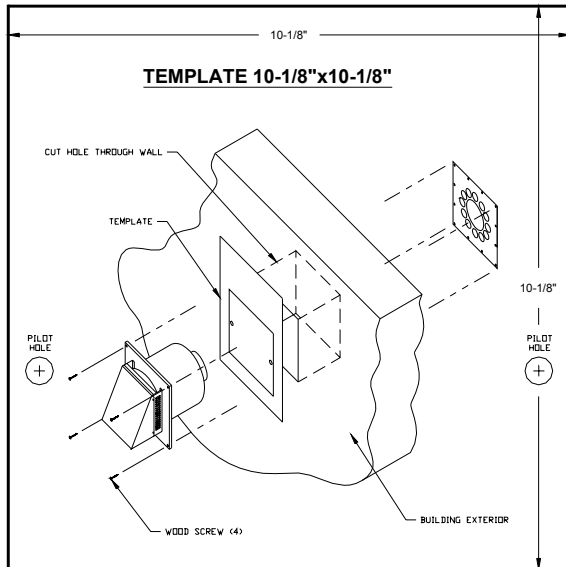

Sample of the FXHOOD mounting template that is supplied with the FXHOOD sidewall vent terminator. The inside vent pipe connection is 4" diameter. There is a larger circular pipe around the inner 4" pipe that maintains clearance. Additionally there are four tabs around the outer pipe that maintain proper clearance to combustibles once installed. These tabs require the installation hole to be square. Rough opening is (10 1/8" x 10 1/8").

Maintenance and Service

WARNING: Always turn off the electrical power supply, turn off the manual gas valve and turn off the manual water control valves whenever servicing.

The unit should be checked once a year by a certified gas technician. If repairs are needed, the repairs should be done by a certified gas technician.

Systems and parts that should be checked at least once a year.

Reference diagrams on pages 13 and 20

1. Venting system
2. Burners –see page 13 for viewing window.
3. Manual operation of the pressure relief valve to insure correct operation.
4. Periodic cleaning of the water filter, refer to figure below.
5. Heat exchanger. Remove the thermistor and check for a mineral coating. A mineral coating on the thermistor requires flushing the heat exchanger with a descaling solution. Scale build up will shorten the life of your water heater, descale heat exchanger thoroughly and repeat annually depending on mineral content of ground water.
6. Flow sensor. Remove the flow sensor from the unit to inspect and clean the component.

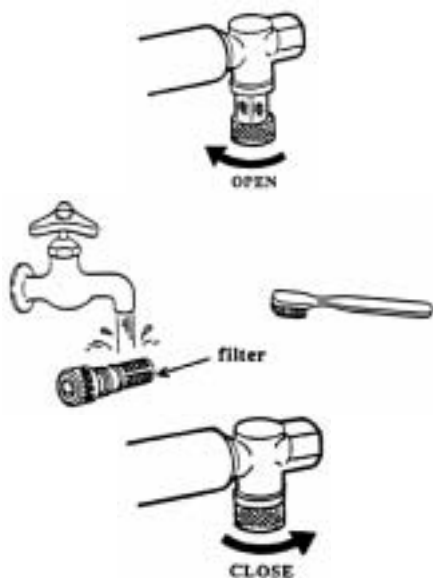

TROUBLE SHOOTING: COMMON QUESTIONS AND ANSWERS

Reference diagrams on pages 13, 19 and 20

- Q: No hot water
Q: The “on” lamp is not lit.
A: After you turn on the power supply, you must wait 30 second to start the unit.
A: Check the Ground Fault Circuit Interrupter test buttons in heater (58) page 20 for a light. If no light comes on after pushing the test reset button, then there is a power supply problem. Be sure the unit is properly grounded.
A: Open the manual gas shut off valve all the way.
Q: While using the appliance the flame went out.
A: Open the manual Gas shut off valve all the way. Check the Inlet Gas Pressure (immediately outside the unit) with the unit running.
A: Clean the filter if necessary. Refer to the maintenance and service section.
A: A minimum water flow of 0.75 GPM is needed to activate your heater.
A: The heater can deactivate if too much cold water is mixed with the hot water at the tap.
Q: When I open the hot water tap and mix it with cold water the water turns cold.
A: A minimum water flow of 0.75 GPM is required to activate your heater. After the heater is activated, the required water flow drops to 0.6 GPM to keep your heater on. If the water flow rate falls below 0.6 GPM because too much cold water is being mixed against the hot water flow at the tap then the burners will turn off automatically.
Q: White smoke comes out from the exhaust vent.
A: During the winter when temperatures are colder the exhaust fumes condense in the air and produce white steam.
Q: When I open a hot water faucet, I do not immediately get hot water.
A: It takes time for the hot water to get from the heater to your faucet.
Q: Even after I turn off the hot water tap, the fan still runs.
A: The fan is designed to be on for a full 70 seconds after the hot water tap is turned off to eliminate all residual flue gases and flue products.
Q: Unit frequently trips on high limit, will reset properly but continues to happen.
A: Descale heat exchanger thoroughly. Repeat annually or more often depending on mineral content of ground water.

These 3 listed symptoms and solutions are to be followed when there is a problem but there is NO error code on the heater or 240TSTAT remote control.

1. Water Isn't Hot Enough

The 240FX can burn gas at a maximum input rate of 165,000 BTUH. This puts a limit on the possible output temperature and flow capabilities (See flow chart on the last page of this manual). If the water isn't hot enough, turn down the flow rate through the unit. If it still isn't hot enough, compare the flow and temperature that is being attained to the 240FX flow vs. temperature chart, see p.22. If the unit is not performing according to the chart, first check that the gas supply line is sized properly, and that the gas pressure is within the required range. If the gas line is okay, check the plumbing for mixing valves, thermostatic valves, scald protection, single handled valves or crossed connections. If the unit is performing in accordance with the flow chart, then it may be undersized for the application.

2. It Takes Too Long to Get Hot Water

The 240FX takes three seconds to ignite, and three more to get up to temperature. The rest of the time needed for hot water to get to a fixture is due to the length of piping between the water heater and the fixture. If the unit seems to be taking longer than six seconds to initiate, check the filter and flow sensor for any debris or damage.

3. The 240FX Will Not Initiate

First check the flow rate through the unit. If the flow is not .75 GPM or greater, the unit will not initiate. Check the inlet filter screen for debris. Then check for a plumbing crossover in the building. To confirm there is no crossover in the plumbing, shut off the cold water supply to the 240FX and then open all hot water faucets. There should not be any water flowing at these faucets. Water running is a sign of a plumbing crossover and it must be corrected.

Press the lower green button on the GFCI inside the unit. If the red light above it does not come on, then there is a problem with the electrical supply to the unit. If that light does come on, hit the green reset button above the light, and look for a small red LED in the lower hole in the middle of the 240FX circuit plate. If this light is not lit, there is a problem with the electrical connection between the GFCI and the circuit plate. Contact CEC for instructions.

Error Codes

The 240FX is self diagnostic for errors. If there is a problem with the installation, venting or operation of the unit, it will give a signal, through a pair of flashing lights on the circuit plate, to communicate the source of the problem. If the unit has a 240TSTAT remote control installed, this will give also a numerical error code. Consult the following chart on page 19 for the meaning of an error code:

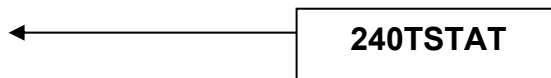

Determine the error by observing the upper and lower lights of the 240FX. The (No) column in the chart below references the error code number on 240TSTAT remote controls.

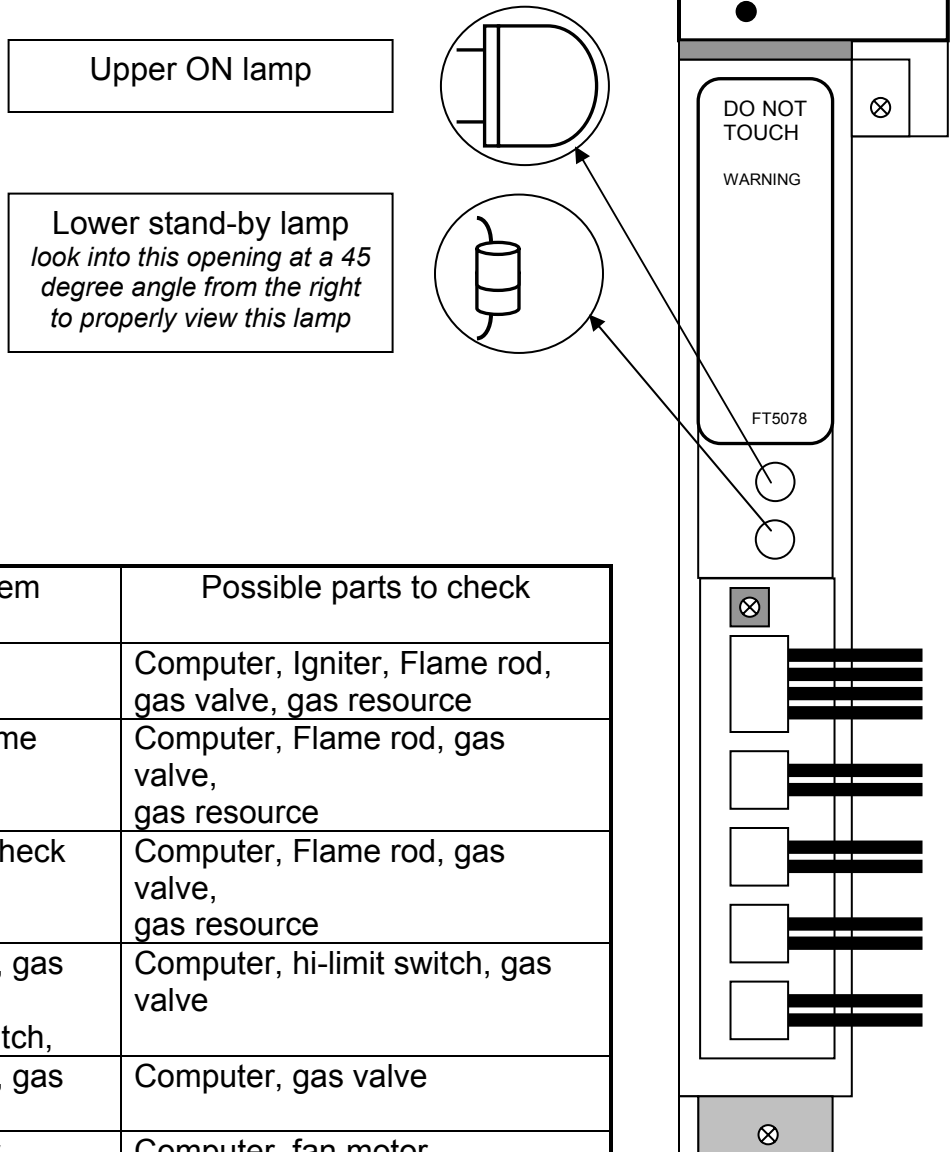

Upper	Lower	No	Problem	Possible parts to check
Blinking	Off	11	Igniter	Computer, Igniter, Flame rod, gas valve, gas resource
		12	Burner flame	Computer, Flame rod, gas valve, gas resource
		72	Pre post check	Computer, Flame rod, gas valve, gas resource
Off	Blinking	14	Computer, gas valve, hi-limit switch,	Computer, hi-limit switch, gas valve
		71	Computer, gas valve	Computer, gas valve
Blinking Together		45	Fan motor	Computer, fan motor
Blinking Alternately		31	Thermister, pressure switch	Computer, thermister, pressure switch
Off	Off	Off	Electric supply	Computer, GFI, fuse, wire, connection outer electric resource

HOUSING COMPONENTS DIAGRAM

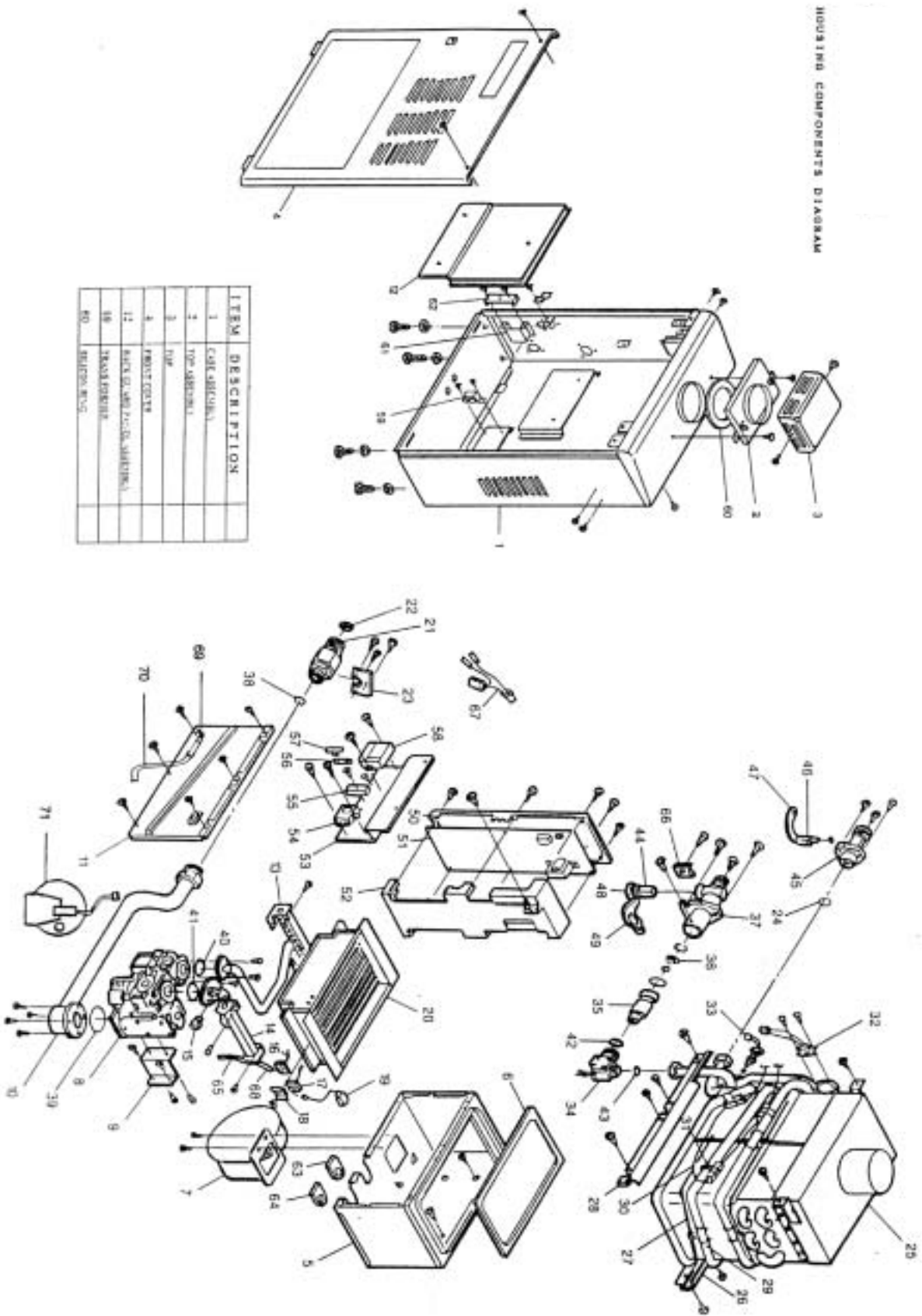

ITEM	DESCRIPTION
1	CABINET
2	TOP ASSEMBLY
3	TOP COVER
4	FRONT COVER
5	BACK COVER
6	FRONT PANEL
7	FRONT PANEL
8	FRONT PANEL
9	FRONT PANEL
10	FRONT PANEL
11	FRONT PANEL
12	FRONT PANEL
13	FRONT PANEL
14	FRONT PANEL
15	FRONT PANEL
16	FRONT PANEL
17	FRONT PANEL
18	FRONT PANEL
19	FRONT PANEL
20	FRONT PANEL
21	FRONT PANEL
22	FRONT PANEL
23	FRONT PANEL
24	FRONT PANEL
25	FRONT PANEL
26	FRONT PANEL
27	FRONT PANEL
28	FRONT PANEL
29	FRONT PANEL
30	FRONT PANEL
31	FRONT PANEL
32	FRONT PANEL
33	FRONT PANEL
34	FRONT PANEL
35	FRONT PANEL
36	FRONT PANEL
37	FRONT PANEL
38	FRONT PANEL
39	FRONT PANEL
40	FRONT PANEL
41	FRONT PANEL
42	FRONT PANEL
43	FRONT PANEL
44	FRONT PANEL
45	FRONT PANEL
46	FRONT PANEL
47	FRONT PANEL
48	FRONT PANEL
49	FRONT PANEL
50	FRONT PANEL
51	FRONT PANEL
52	FRONT PANEL
53	FRONT PANEL
54	FRONT PANEL
55	FRONT PANEL
56	FRONT PANEL
57	FRONT PANEL
58	FRONT PANEL
59	FRONT PANEL
60	FRONT PANEL
61	FRONT PANEL
62	FRONT PANEL
63	FRONT PANEL
64	FRONT PANEL
65	FRONT PANEL
66	FRONT PANEL
67	FRONT PANEL
68	FRONT PANEL
69	FRONT PANEL
70	FRONT PANEL
71	FRONT PANEL

PARTS LIST (the part number is EK followed by the ITEM number)

ITEM	DESCRIPTION	ITEM	DESCRIPTION
1	CASE ASSEMBLY	2	TOP ASSEMBLY
3	OUT DOOR VENT CAP	4	FRONT COVER
5	COMBUSTION CHAMBER	6	PACKING
7	FAN MOTOR	8	GAS VALVE UNIT
9	VALVE FIXING PLATE	10	GAS IN PIPE
11	COMBUSTION CHAMBER FRONT	12	BACK GUARD PANEL
13	LEFT MANIFOLD	14	RIGHT MANIFOLD
16	SPARK ELECTRODE	17	FLAME DETECTOR
18	FIXING PLATE	19	FLAME DETECTOR WIRE
20	BURNER ASSEMBLY	21	GAS INLET
22	GAS FILTER	23	FIXING PLATE
24	SEAL PACKING	25	HEAT EXCHANGER ASSEMBLY
26	HEAT EXCHANGER FIXING PLATE	27	OVER HEAT CUT OFF FUSE
28	HEAT EXCHANGER FIXING PLATE	29	FUSE FIXING PLATE
30	HEATER BLOCK ASSEMBLY	31	HEATER FIXING PLATE
32	HI - LIMIT SWITCH	33	THERMISTOR ASSEMBLY
34	FLOW SENSOR	35	WATER GOVERNOR CASE
36	WATER GOVERNOR	37	WATER INLET
38	O-RING	39	O-RING
40	O-RING	41	O-RING
42	O-RING	43	JOINT PACKING
44	FILTER	45	WATER OUTLET
46	DRAIN PLUG	47	DRAIN BAND
48	DRAIN PLUG	49	DRAIN BAND
50	CONTROL BOX "A"	51	CIRCUIT PLATE
52	CONTROL BOX "B"	53	PLATE
54	IGNITER	55	FUSE BOX
56	FUSE	57	FUSE COVER
58	GROUND FAULT INTERRUPTER	59	TRANSFORMER
60	SILICON RING	63	RUBBER BUSHING "A"
64	RUBBER BUSHING "B"	65	IGNITION WIRE
66	SEAL PLATE	67	THERMOSTAT
68	SILICON CAP	69	PRESSURE SWITCH PORT
70	SILICON TUBE	71	PRESSURE SWITCH

Flow Rate and Temperature Rise with varying inlet water temperatures

The 240FX has been set at the factory to deliver 122° F (50° C) water. This is electronically controlled by the computer in the heater.

The delivered hot water temperature will depend upon both the inlet water temperature and the hot water flow rate, refer to the chart below. The 240FX has been set at the factory to raise the temperature of cold inlet water from as low as 45 F degrees up to 122 F degrees (a 77 F degree rise). With 45 F degree inlet water the 240FX can only reach 122 F for flows up to but not exceeding 3.5 gallons per minute (gpm). If the flow is more than 3.5 gpm or if the inlet water temperature is less than 45 F the degree rise will be less. The 240FX will target 122 F or a 77 F maximum degree rise, whichever comes first.

If the inlet water temperature is warmer than 45 F degrees the 240FX will be able to reach 122 F degrees at higher flow rates, for example if the inlet water temperature is 60 F degrees the 240 FX will produce 122 F degrees up to a flow of 4.3 gpm.

Flow Rate	<u>Inlet water temperature (F)</u>		
	45	50	60
0.75	122	122	122
1	122	122	122
1.5	122	122	122
2	122	122	122
2.5	122	122	122
3.5	122	122	122
3.7	117	122	122
4	112	117	122
4.3	107	112	122
4.5	105	110	120
5	98	103	113
5.3	95	100	110

Five Year Limited Warranty

General

240FX warranty is honored by the Manufacturer (Takagi USA) through Controlled Energy Corp. Controlled Energy Corp. (CEC) will furnish a replacement heat exchanger and will furnish a replacement of any other part which fails in normal use and service within the applicable periods specified below, in accordance with the terms of this warranty. The CEC replacement will be warranted for the unexpired portion of the original warranty. This warranty will be valid only for water heaters in possession of the original purchaser as recorded on the warranty card.

The Heat Exchanger

If the heat exchanger fails within five (5) years after the original installation and operation, CEC will furnish a replacement heat exchanger. However, if the water heater is installed in other than a single family dwelling this heat exchanger warranty is limited to two (2) years from date of original installation and operation.

All Other Parts

If any other part fails within two (2) years after original installation and operation, CEC will furnish a replacement part free of charge.

Shipping Costs

In addition to supplying the replacement part(s), CEC will pay transportation costs for these parts to a convenient delivery point near you selected by CEC, such as a local AquaStar dealer or distributor.

Service Labor Costs

This warranty does not cover any labor costs associated with service, removal or re-installation of part(s). All such costs must be borne by the Purchaser.

Exceptions

This warranty will not apply:

1. to defects or malfunctions resulting from failure to properly install, operate or maintain the unit in accordance with the printed instructions provided;
2. to damage or abuse, accident, neglect or freezing and other acts of nature;
3. to damage resulting from operation with any safety devices disabled;
4. **to failure of the heat exchanger resulting from the operation of the water heater in a corrosive atmosphere or at water temperatures exceeding the maximum rating, or if the water heater is not supplied with potable water.**
5. to defects or damage cause by any attachment or modification, including any energy-saving device.

Note: The water heater must be free of damaging scale deposits and not subject to gas pressures greater than those shown on the rating plate, which must not be altered, defaced or removed.

How to Make a Claim

Any claim for warranty service should be made to your local dealer or distributor, or to CEC. If CEC, please contact the Service Dept: Controlled Energy Corp. 340 Mad River Park, Waitsfield, VT 05673 Ph: 800-642-3111

In most cases, the dealer or distributor will be able to promptly honor your claim and subsequently notify CEC. However, **all replacements are made subject to validation by CEC of in-warranty coverage.** The damaged or defective item must be made available in exchange for the replacement.

Miscellaneous

No one is authorized to make any other warranties on behalf of CEC. **It is expressly understood that the replacement warranty of CEC shall be in lieu of any and all other warranties, express or implied, including warranties of merchantability or fitness for a particular use or purpose, and further that CEC shall not be liable for any loss or damage directly or indirectly arising from the use of the hot water heater, or for any consequential damages arising from such use (including damages from water leakage).** CEC's sole liability with respect to any defect shall be for the replacement of the defective part(s). Some states do not allow such limitations and exclusions, so the above may not apply to you.

This warranty gives specific legal rights. You may also have other rights, which vary from state to state. In the event that warranty service is required, reasonable proof of the effective date of installation and operation must be provided; otherwise, it may not be possible to honor this warranty.

01.2002