

Service Bulletin G3-10

Models: 2400ES, 2700ES, 715ES, C800ES, C920ES, C920ESC, Evolution 500, Integra 500

EC error code troubleshooting



BOSCH

Introduction

Follow the procedures below and report results to Bosch Technical Support. This will assist in determining the cause and solution to the problem.

EC Error code explanation:

Loss of burner flame during hot water use.

Tools needed:

- ▶ Phillips head screwdriver
- ▶ Manometer

Procedure

Remove cover from heater (see Section 2.2 in Installation Manual). Check for spark and flame through window in heat exchanger with water flowing (Figure 1, pos. 1).

If there is spark and flame but flame goes out with hot water still flowing:

1. Measure gas pressure under full load with manometer. See Bulletin G3-03 or Installation Manual for details. Have gas technician call Bosch Water Heating from heater to report readings. Otherwise, record exact readings in manual or below:
 - a. Static: _____"WC, operating (P1): _____"WC
 - b. If pressure is inadequate, it must be raised to at least the minimum before further troubleshooting.
2. Check for correct gas type on label on right side of heater cover. The heater's gas type can also be confirmed using the control board diagnostics feature (see installation manual). If gas type is incorrect, heater will not operate correctly. For models 715ES, 2400ES and 2700ES, it is possible to convert the heater gas type using a combustion gas analyzer and a conversion kit (part number 8 719 002 176).
3. Check for blocked exhaust/intake venting and terminations.
4. Check for correct minimum exhaust length of 3 feet. See Installation Manual section 3.3.
5. Check for cross contamination between separate intake and exhaust terminations. Minimum distance between terminations is 3 feet. See Installation Manual section 3.3. **This minimum distance does not apply for concentric terminations.**
6. Check for broken yellow paint on fuel/air mixture adjustment screws. If either adjustment has been changed, the fuel/air mixture could be incorrect. Adjustment can only be made with the use of a combustion gas analyzer. See Bulletin G3-12 for adjusting CO₂.

Figure 1

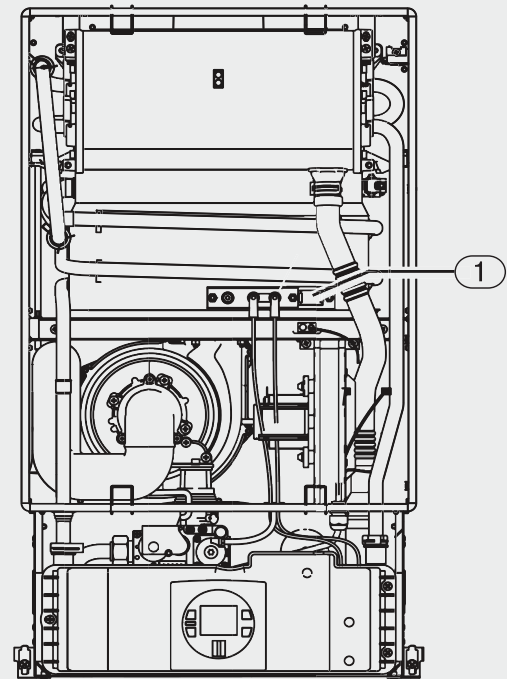

C 920 ES/ESC shown - heater design may vary slightly depending on model

7. Clean or replace electrodes if damage is present. See Bulletin G3-23.
8. Check P1 and P2 fan speed settings.
 - a. For heater serial numbers starting with FD887 and higher, refer to bulletin G3-15.
 - b. For heater serial numbers starting with FD886 and lower, refer to installation manual, section 3.11.4 Vent length calculation
9. If altitude where heater is located is above 2000 feet, CO2 must be recalibrated with a combustion gas analyzer. See Bulletin G3-12.

Call Bosch Water Heating with troubleshooting results, exact gas pressure readings or further questions. If a gas technician is at the heater, technician should call from heater with Unit number (our record referring to consumer's location and heater details). If no Unit record has been started, we will need consumer's name, address, phone number, heater model name and number, serial number, date of installation and installation details.



BOSCH

Bosch Thermotechnology Corp.
50 Wentworth Avenue
Londonderry, NH 03053

Tel: 1-866-642-3198
Fax: 1-603-584-1681
www.boschhotwater.com